

Experiences from Broadband Rollout and Future Steps in KT

HONGSEOK KIM



Hongsoek Kim (27) received his B.S.E.E. and M.S.E.E. degrees from the Seoul National University in 1998 and 2000, respectively. Since 2000 he has been working in Korea Telecom (KT) as a member of technical staff. His research interests are broadband access network systems such as ADSL, VDSL, BPON and currently up to EPON. Since FS-VDSL started, he is mainly involved in FS-VDSL for the next broadband access network in KT.

innotobe@kt.co.kr

This paper provides the overview, experiences and future steps on broadband access networks in Korea Telecom (KT). The overall number of high speed Internet users in Korea, by July 2002, is over 9.2 million including 5.1 million ADSL subscribers, while KT has 3.8 million ADSL subscribers. The number has grown rapidly during the last three years. This is the fastest and largest broadband access rollout. It is now, however, almost matured, and KT is actively seeking alternative solutions for next broadband access. In this paper, we first review various kinds of access network topologies in KT; central office based ADSL, FTTC ADSL and Home LAN. Then, we provide up-to-date details of experiences in ADSL deployment such as traffic pattern, protocols, link performance, interoperability and crosstalk in real field. Finally, based on the experiences and current status, we briefly show future steps on broadband access networks including VDSL, PON, Metro Ethernet and MSPP.

1 Introduction

1.1 Statistics of Broadband Access in Korea

The Internet is so popular in Korea. According to the Korea Network Information Center (KRNIC), which is the Internet domain administrator in Korea, the number of Internet users is over 25 million by June 2002 as shown in Figure 1. It means about 58 % of Koreans use the Internet; that is one of the highest ratios in the world. The growth rate, however, has now slowed down somewhat.

Table 1 shows the broadband statistics in Korea. The number of high speed Internet users, mainly

consisting of ADSL, CATV and Home LAN users, is over 9.2 million. There are 5.1 million ADSL subscribers, while KT has 3.8 million. The strongest point of ADSL is that it reuses the existing copper wires for Plain Old Telephone Service (POTS), so there is no need for new installation of access network infrastructure unlike CATV system. This makes ADSL the most popular service amongst various access technologies.

The CATV is the second popular with 3.3 million users followed by 0.6 million Home LAN users. Home LAN is a kind of customer premises communication and intended for users in apartment complexes. Leased line, mainly

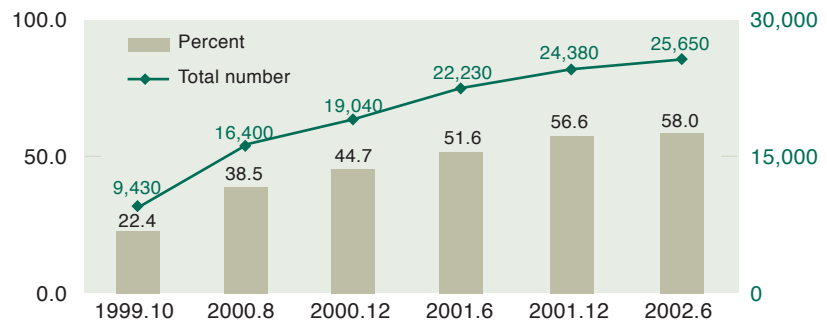

Figure 1 The growth of Internet users in Korea (unit: thousand)

| | KT | HTI | ThruNet | Other ISPs | Total |
|-----------------|------------------|------------------|------------------|------------------|------------------|
| ADSL | 3,782,437 | 1,151,448 | 3,511 | 207,900 | 5,145,296 |
| CATV | 0 | 1,237,343 | 1,298,676 | 734,705 | 3,270,724 |
| Home LAN | 537,951 | 16,740 | 0 | 60,947 | 615,638 |
| Etc. | 137,764 | 55,697 | 2,086 | 20,064 | 215,611 |
| Total | 4,458,152 | 2,461,228 | 1,304,273 | 1,023,616 | 9,247,269 |

Table 1 Broadband access users

Table 2 Applications in the Internet

| | Web surfing | Online game | Email | Education | Shopping Reservation | Chatting | eCommerce | Etc. |
|--------|-------------|-------------|--------|-----------|----------------------|----------|-----------|-------|
| 2001.6 | 61.7 % | 15.2 % | 13.5 % | 3.4 % | 1.6 % | 1.8 % | 1.4 % | 2.4 % |
| 2002.6 | 49.1 % | 25.7 % | 13.5 % | 2.7 % | 2.3 % | 1.8 % | 1.4 % | 3.5 % |

Table 3 Protocols used in the Internet

| Protocol | HTTP | P2P | WMP_TCP | Telnet | Real_UDP | Etc. |
|----------|------|-----|---------|--------|----------|------|
| Percent | 72.2 | 4.1 | 3.9 | 2.65 | 0.69 | 2.3 |

fiber, connects the Internet to the apartment complex, and users in apartments are interconnected locally by various copper technologies such as TLAN, Ethernet, SHDSL or VDSL.

Table 2 shows users' preferences in the Internet. It indicates that web surfing to get some information is the highest preference of Internet users. The second preference is a network game. In Korea, the Internet online games are so popular, and it is easy to find network gamers in PC rooms that are a kind of Internet café offering network games and high-speed access for as little as one or two dollars per hour. Even though many users can access the Internet in their own homes now, they still like to play network games in PC rooms. Shopping, reservation and eCommerce do not yet occupy much of the portion, but they are expected to grow steadily in the near future.

Internet usage according to age indicates that 90 % of children and teenagers and 86 % of people in their twenties are accessing the web; further, almost 100 % of students from elementary school to university are using the Internet. These days, the ratio of men in their thirties using the Internet is steadily rising. As regards PC environment, PC penetrates 78.6 % of the total number of homes in Korea, and 86.9 % of PC equipped homes can access the Internet. It means that about 70 % (0.786×0.869) of a total of 13.4 million homes are penetrated by high speed Internet. Thus, we think the broadband access market is now somewhat saturated, and the growth rate is not so high these days.

1.2 Primary Factors of the Fastest and Largest Broadband Rollout in Korea

There are several factors for this rapid growth. First, the government strongly encourages Information Technology (IT) industries. Accordingly, many IT enterprises such as Internet Service Providers (ISPs) and network equipment vendors as well as IT venture companies are still actively emerging. Thus, government policies

and voluntarily induced individuals construct abundant IT infrastructures.

Second, the regulator, the Ministry of Information and Communications (MIC) introduced hard competition in IT industry. Thus, ISPs have little choice but to cut down the broadband access tariffs and provide good services for their survival. The induced low ADSL tariff in Korea, e.g. 25 to 33 dollars per month, indirectly encouraged the broadband tariffs of other countries to be down.

The third reason is the Koreans' strong preference for high technologies. The fact that 68 % of the Koreans have mobile phones is a good example. They also need the Internet for various purposes: educational usage, cyber stock trading, Internet banking and so on. For example, students in elementary schools are asked to send in their homeworks using the Internet, so parents with a high educational fever cannot help subscribing to the broadband access.

The fourth reason comes from the social aspect, more specifically Korean nationality and culture. To satisfy high demands in network game and the Internet, many PC rooms have sprouted like mushrooms all over the country during the last four years. Students from elementary schools to universities as well as adults are their regular customers. The Koreans have a tendency of behaving in a group, and PC rooms are crucial as meeting places for network gamers and Internet users. Thus, at the time when broadband access was not widely used, PC rooms made certain cyber cultures amongst young people. Accordingly, while using the Internet in PC rooms, they began to need Internet access in their own homes as well, and this greatly helped access networks to be deployed. Moreover, they sometimes feel like purchasing something on impulse if the majority of their friends already have it. They might feel some sense of isolation if they do not have broadband access lines in their own homes.

The final reason is the high population density induced from the distinctive housing styles. We

can categorize the housing styles in three main types: One is apartment complexes, another is housing complexes including multiple dwelling units (MDU) or multiple floor-row houses, and the third is normal houses. For simplicity, housing complexes and normal houses will be collectively called residential houses. Here is an example of population density measured in the field. We define the population density as the number of residents per $100 \times 100 \text{ m}^2$. The measured densities in example areas are 215 for an apartment complex, 306 for a housing complex, and 125 for normal houses. Thus, even areas with normal houses have a population density which is notably high compared to that of apartment complexes or housing complexes. As regards the portion of housing styles, normal houses occupy 50 %, apartment complexes occupy 37 % and housing complexes occupy 6 %. All of these housing patterns enable cost-effective deployment.

2 Basic Topologies of Broadband access in KT

2.1 Local Loops Condition and Basic Broadband Access to Date

Table 4 shows the cumulative distribution of users and local loops respectively. 52 % of users are within 2 km from the central office, and the average distance from the central office to the users is 2,440 m. 57.7 % of local loops are within 2 km, and the average distance is 1,912 m. 80 % of users as well as local loops are within 3 km.

2.2 ADSL

2.2.1 Central Office Based ADSL (CO ADSL)

Figure 2 shows two kinds of ADSL access networks in KT. The first one is central office based ADSL, hereafter called CO ADSL. In this scheme DSLAM is located in the central office,

and users are directly connected to DSLAM via ADSL. 90 % of installed ADSL in KT are CO ADSL, and it is mainly targeted for users in residential houses. KT has a strong point with CO ADSL because only KT has local loops to subscribers in residential houses, and even though local loop unbundling (LLU) is underway in accordance with the MIC recommendation, other ISPs are hardly renting KT local loops yet. In fact, HTI is providing only FTTC ADSL to users in apartment complexes. HTI or ThruNet serve users in residential houses with CATV.

2.2.2 FTTC ADSL

The second type of ADSL is based on fiber loop carrier. FTTC ADSL mainly serves users in apartment complexes as shown in Figure 2, but sometimes it also serves users in residential houses beyond 3 km from the CO. The ONU is placed in the apartment, so it can serve regardless of copper loop length between CO and apartment complex. In KT this scheme is sometimes called Remote DSLAM. 10 % of installed ADSL in KT are based on FTTC ADSL.

2.3 Home LAN

Besides ADSL, another major broadband access is Home LAN. Home LAN mainly consists of two types; one is Building and Apartment (B&A), and the other is NTOPIA. Two methods are based on Ethernet in layer 2 and commonly targeted for users in apartment complexes.

2.3.1 B&A

At an early stage of broadband access in Korea, other ISPs were offensively providing broadband access into apartment complexes. In order to defend the broadband market in apartments, KT was providing B&A. However, it is not recommended these days due to low bandwidth and some management problems. B&A consists of leased line and LAN. Leased line is connected between KORNET and the apartment complex.

| Distribution | ~ 1 km | ~ 2 km | ~ 3 km | ~ 4 km | ~ 5 km | ~ 6 km | Average distance |
|--------------|--------|--------|--------|--------|--------|--------|------------------|
| Users | 15.7 % | 52.0 % | 79.7 % | 85.4 % | 98.3 % | 99.4 % | 2,440 m |
| Local loops | 27.1 % | 57.7 % | 80.7 % | 93.2 % | 98.7 % | 99.8 % | 1,912 m |

Table 4 Cumulative distribution of users and local loops

| | ADSL | | Home LAN | | ETC | Total |
|---------|---------|-----------|----------|--------|-----|-------|
| | CO ADSL | FTTC ADSL | B&A | NTOPIA | | |
| Percent | 76 % | 8 % | 12 % | 3 % | 1 % | 100 % |
| | 84 % | | 15 % | | | |

Table 5 Basic broadband access networks

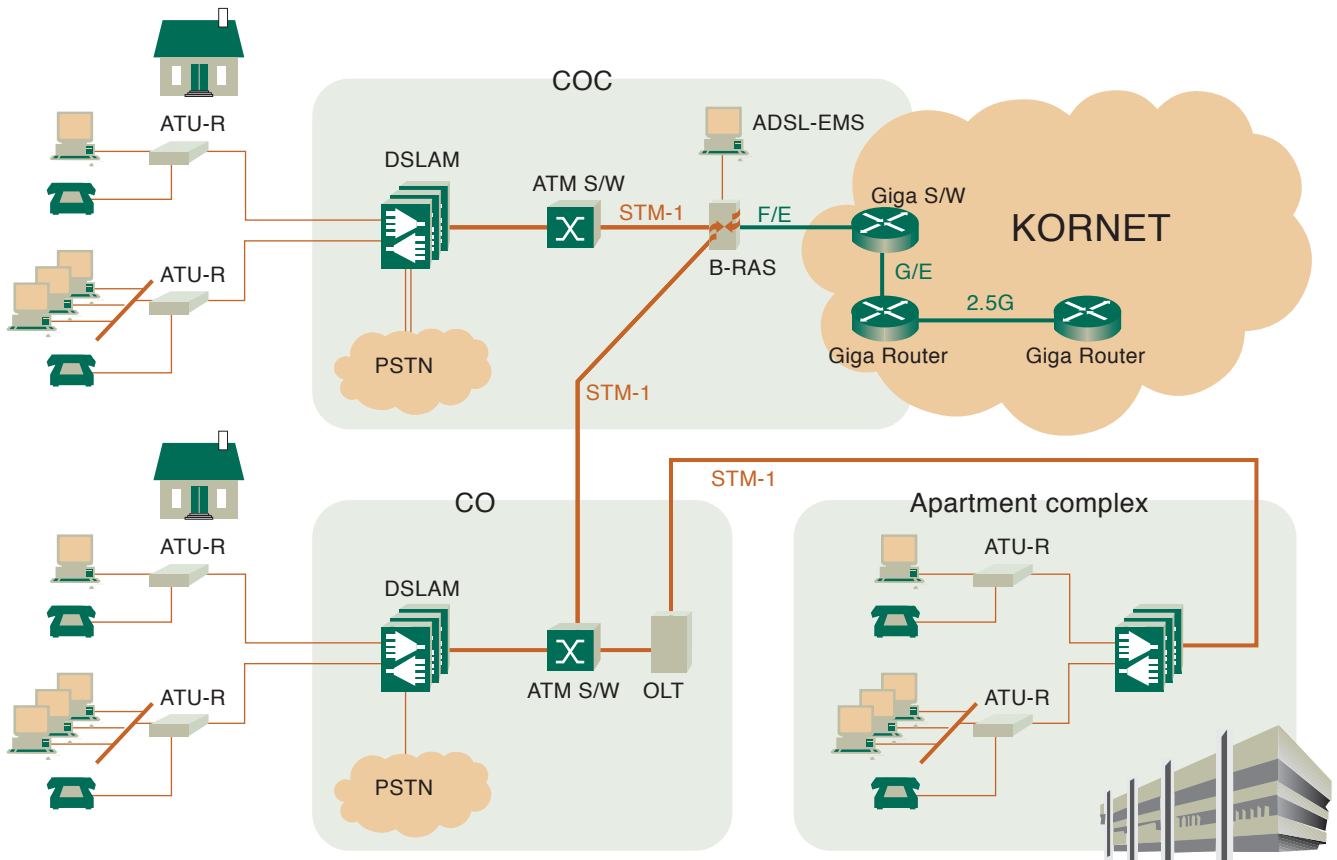

Figure 2 The topology of ADSL access network in KT

A small router is placed in the apartment complex and Ethernet interconnects each user with a router. PHY of B&A was based on TLAN, which stands for Time-division duplex LAN and was developed by some Korean venture com-

pany. B&A can provide high speed in the local network within apartments, but usually the capacity of the leased line is low. Thus, bandwidth per user to the backbone is not high compared to other broadband access.

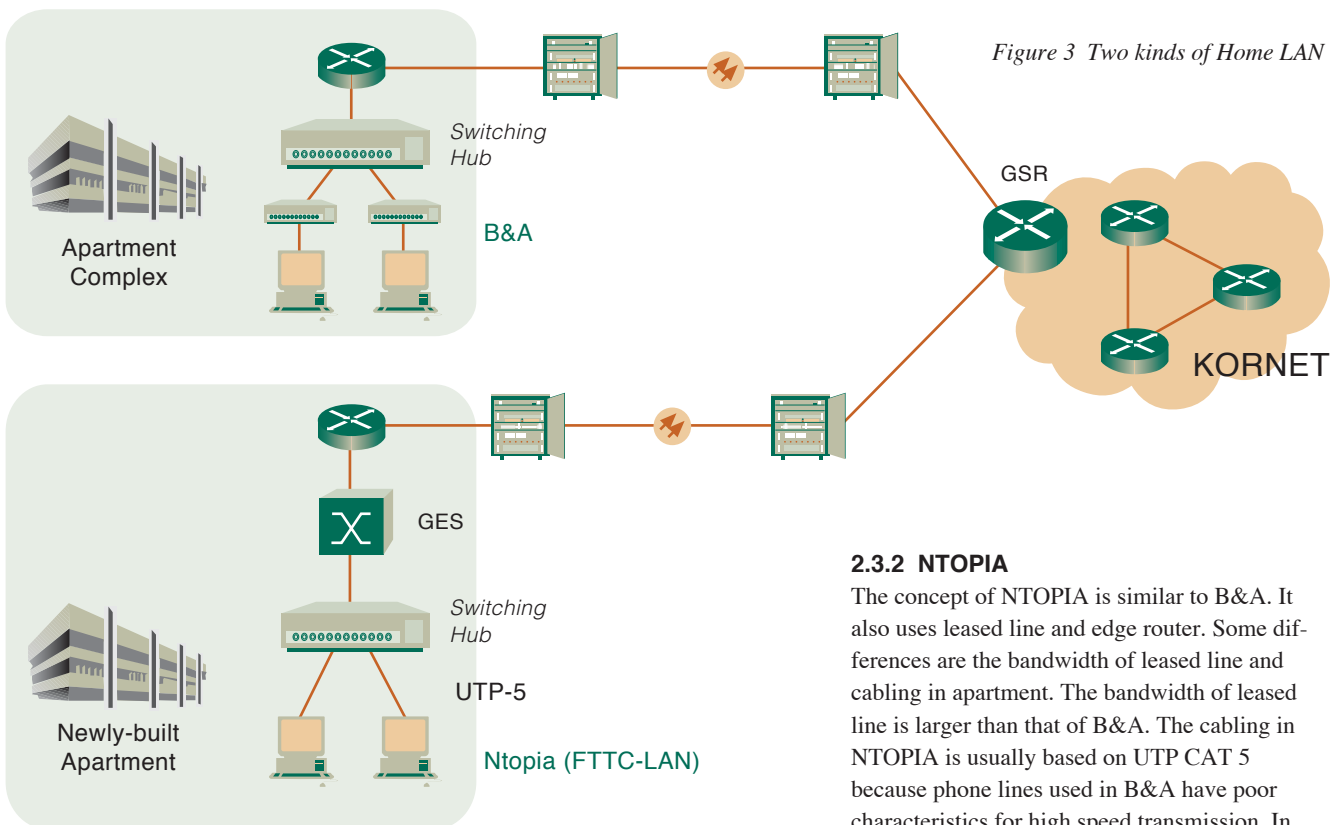

Figure 3 Two kinds of Home LAN

2.3.2 NTOPIA

The concept of NTOPIA is similar to B&A. It also uses leased line and edge router. Some differences are the bandwidth of leased line and cabling in apartment. The bandwidth of leased line is larger than that of B&A. The cabling in NTOPIA is usually based on UTP CAT 5 because phone lines used in B&A have poor characteristics for high speed transmission. In

new buildings and apartments, it is common to be equipped with more than UTP CAT5. The apartment equipped with UTP CAT 5 and qualified for broadband access is usually called Cyber Apartment. The regulator, MIC, evaluates the conformance of broadband access when new apartments are built. Then, MIC categorizes the level of the apartment in accordance with broadband accessibility and cabling condition. So, NTOPIA is the specially prepared broadband access for this kind of Cyber Apartment. This kind of NTOPIA is called NTOPIA-E, which stands for NTOPIA Ethernet. According to the condition of local loop in apartment complexes, the PHY of NTOPIA can be various types, such as 10Base-T, 100Base-T, SHDSL or VDSL. In case of no UTP, PHY is based on SHDSL or VDSL instead of 10Base-T or 100Base-T. They are called NTOPIA-S or NTOPIA-V respectively. KT is actively deploying NTOPIA-E and NTOPIA-S though they do not occupy many portions yet, as shown in Table 5. KT has also started to deploy NTOPIA-V even though ITU-T VDSL standardization is not finished.

2.4 IEEE 802.11b (NETSPOT)

The growth of wired broadband access has now slowed down, and KT expects wireless LAN to be the next leader in broadband access. Using IEEE 802.11b, KT started the wireless LAN service called NETSPOT already in April and is actively installing Access Points around the country. NETSPOT and ADSL can be combined for wireless as well as wired broadband access; wireless access in the home and wired access out of the home.

2.5 Regional Broadband Network

Figure 4 shows the topology of Regional Broadband Network. It connects DSLAMS and Broadband Remote Access Server (B-RAS) to KORNET, which is the backbone Internet in KT. In Central Office Concentrator (COC), B-RAS and ADSL Element Management System (EMS) are

installed. The operator uses ADSL EMS for management and maintenance of DSLAM as well as provision and management of ADSL services. One B-RAS, a gateway to the Internet, terminates about 150,000 to 200,000 ATM PVCs from several DSLAMs. There are about 40 COCs around the country. One COC accommodates 10 to 15 central offices (COs).

There are about four hundred COs around the country, and one CO usually accommodates 10,000 to 15,000 subscribers. In CO, the operator only uses Command Line Interface (CLI) to manage DSLAM, but most functions are read only, and few functions are writable.

2.6 Contents Delivery Network (CDN)

The real time traffic protocol such as UDP does not occupy many portions, but real time multimedia traffic is expected to grow rapidly. KT is constructing CDN to effectively support this traffic. Figure 5 shows the topology of CDN. There is one main node in Seoul and ten regional nodes in other major cities. Regional nodes are cache servers for popular contents, and dually connected to the main node via satellite and leased line/ATM. The number of regional nodes has started to grow. Its aim is to support 1 Mb/s stream based video around the whole country. Currently, many video service providers are using CDN, and KT is starting an IP-based VoD commercial service based on CDN.

2.7 Branding and Tariffs

Table 6 shows the branding and tariffs. All kinds of broadband access have the unified name called MEGAPASS. The tariffs are discounted in accordance with long term contracts as shown in the table.

MEGAPASS PREMIUM is an ADSL service with up to 8 Mbit/s / 640 kbit/s. MEGAPASS LITE is an ADSL service with up to 2 Mbit/s /

Figure 4 Regional Broadband Network

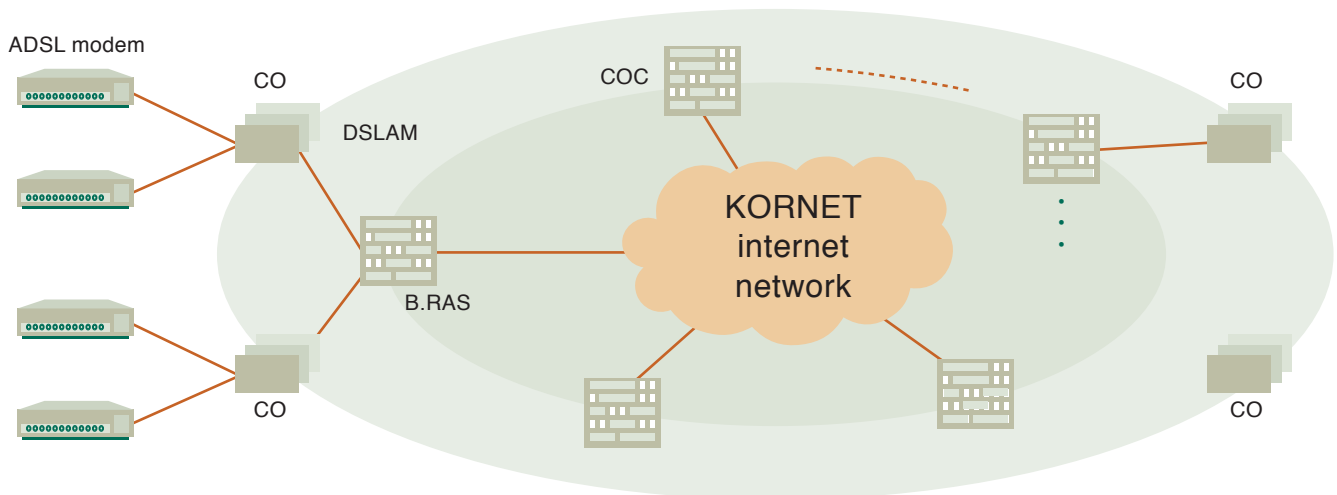

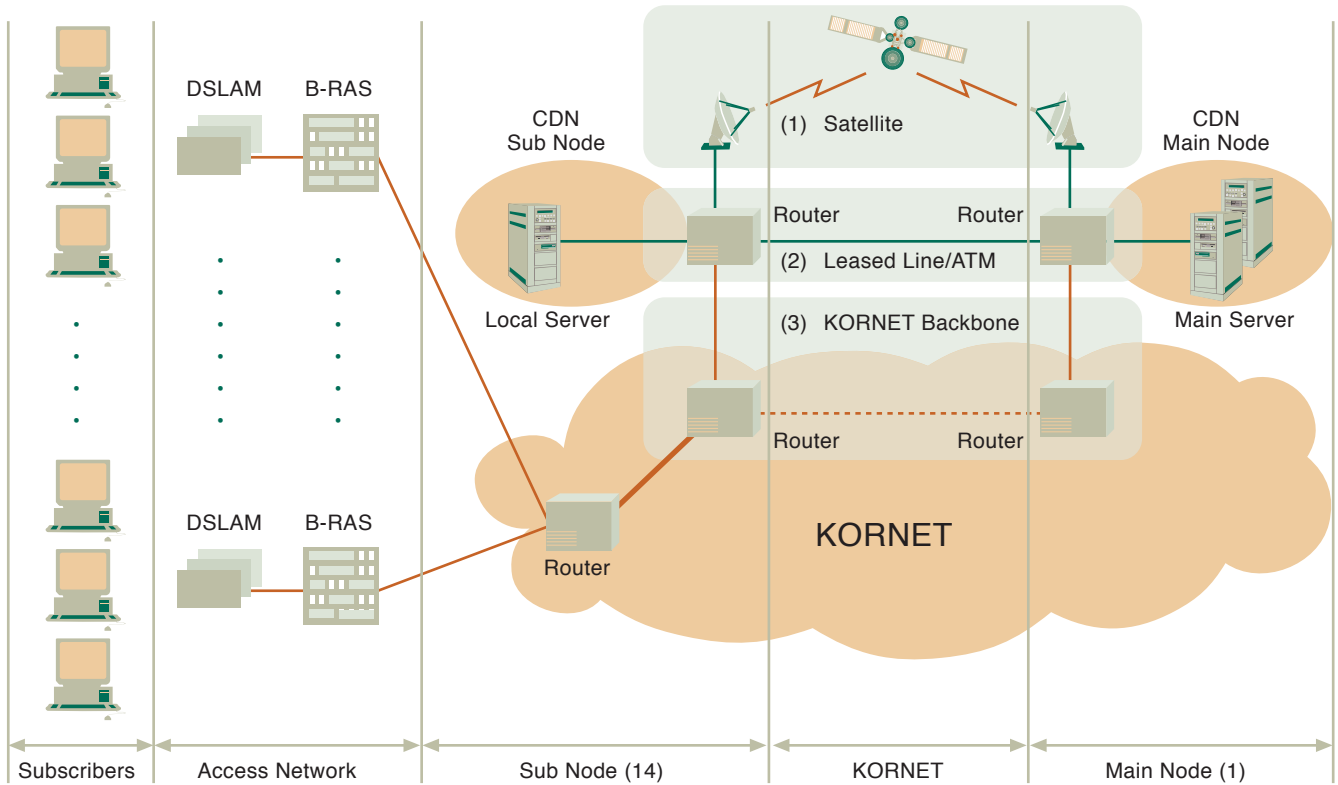

Figure 5 Contents Delivery Network

256 kbit/s. Since ADSL G.992.1 can support these two kinds of services, KT did not adopt ADSL G.992.2. The most popular protocol in KT ADSL is PPPoE with external modem.

From the end user's viewpoint, MEGAPASS NTOPIA is not so different from the two services above. PHY of NTOPIA can be various kinds, such as 10BASE-T, SHDSL or VDSL, and the speeds also vary as denoted vaguely in Table 6. The tariff of NTOPIA shown in Table 6 is for one user, and additional users have to pay US\$ 12. Thus, NTOPIA can accommodate up to 4 users.

MEGAPASS MyIP and MEGAPASS MultiIP are also using ADSL G.992.1, but they have a different IP address scheme. PREMIUM, LITE or NTOPIA are based on dynamic IP addresses, but MyIP and MultiIP have fixed IP addresses. So, they enable users to operate their own servers. While PREMIUM, LITE or NTOPIA are mainly for residential users, MyIP or MultiIP are suitable for SOHO users. We should note, however, that the boom of the Internet is mainly driven by residential users, especially LITE users. 80 % of ADSL users are using LITE. It means that 2 Mbit/s is enough for the Internet access. On the contrary, MyIP or MultiIP users are quite small compared to LITE users.

Table 6 Branding and tariffs

| | Application | Modulation | Speed | < 1 yr | 1 yr (5%) | 2 yrs (10%) | 3 yrs (15%) |
|--------------------------|-------------------------|---------------------|--------------------------------------|--------------------|-----------|-------------|------------------------|
| MEGAPASS PREMIUM | 1 user (PPPoE/PPP) | ADSL (VDSL) | D: 8 Mbit/s U: 640 kbit/s | 40,000 (33 US\$) | 38,000 | 36,000 | 34,000 |
| MEGAPASS LITE | 1 user (PPPoE/PPP) | ADSL | D: 2 Mbit/s U: 256 kbit/s | 30,000 (25 US\$) | 28,500 | 27,000 | 25,500 |
| MEGAPASS NTOPIA | 1 user + 3 (PPPoE) | Ethernet SHDSL VDSL | D: 2 ~ 13 Mbit/s U: 2 ~ 13 Mbit/s | 36,000 (30 US\$) | 34,200 | 32,400 | 30,600 |
| MEGAPASS MyIP | 1 IP-3 user (Layer 2) | ADSL | D: 1.5 Mbit/s U: 384 kbit/s | 80,000 (67 US\$) | 76,000 | 72,000 | 68,000 |
| MEGAPASS MultiIP | 5 IP-13 users (Layer 3) | ADSL | D: 2 Mbit/s U: 512 kbit/s | 180,000 (150 US\$) | 171,000 | 162,000 | 153,000 |
| Monthly modem rental fee | | | | 3,000 (2.5 US\$) | 3,000 | 3,000 | 3,000 *free > 3 yrs |

One thing we have to keep in mind is that the denoted speeds are theoretical upper limits, and they can be different from the denoted speed in accordance with several conditions such as loop length, loop condition and noise. Nevertheless, the marketing and advertising based on the maximum speed help the growth of broadband access. Recently, however, the regulator, MIC, is planning to force ISPs to guarantee the minimum speed according to the Service Level Agreement (SLA). It is expected to be valid from October, and MIC and ISPs are now discussing the detailed principles and procedures.

3 Experiences from the Field

3.1 Statistics of ADSL Traffic

Figure 6 shows an example of active PPP connections in a day. In this graph, the maximum is about 35 %, and the peak time is about 3 p.m. It shows the maximum portion of concurrent PPP users to be just 35 %.

Figure 7 shows daily average traffic measured in B-RAS that accommodates four DSLAMs. Note that the downstream traffic is five times that of upstream in this graph. The peak time is from 10 p.m. to 2 a.m. Since peak time traffic is important for network design, we analyze the characteristics of ADSL traffic using only peak time traffic. The measured peak downstream rate per user was 11.1 kbit/s, and the measured peak upstream rate per users was 2.9 kbit/s. Assuming the maximum ratio of concurrent users is 35 %, the peak downstream rate per active user is estimated as 31.7 kbit/s. In general, one DSLAM equipped with STM-1 has around 1300 subscribers, so the peak rate from one DSLAM would be 14.4 Mbit/s. However, these statistics are provided only as an illustrative example and can be different according to the time and the location of measurement.

3.3 ADSL Loop Management (ATLAS)

KT has POTS management systems named TIMS and TOMS. Telephone-service Integration Management System (TIMS) matches the phone number with the exact physical line number. Telephone Outside-plant Management System (TOMS) stores the line number and its corresponding line configurations such as installed location with map, wire gauge, length, insulated material, and other electrical characteristics. Based on TIMS and TOMS, KT developed ADSL Transmission Line Analysis System (ATLAS) [2]. Figure 8 shows the integration of ATLAS, TIMS and TOMS. When a new end user asks for ADSL service, ATLAS can be used for pre-qualification by estimating the ADSL link speed based on the information from TIMS

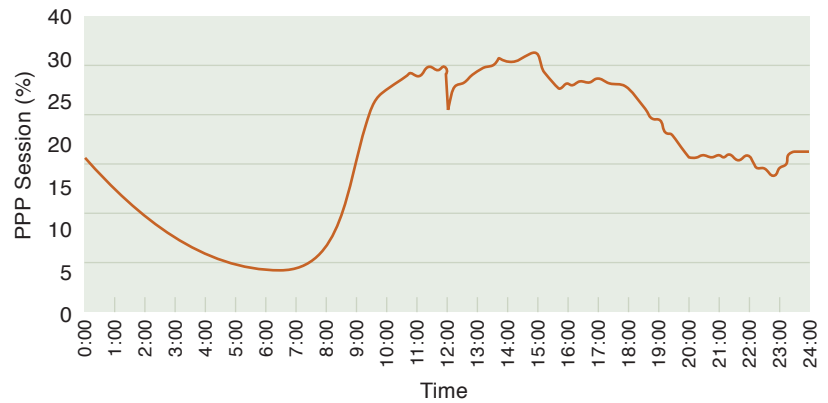

Figure 6 Ratio of active PPP connections

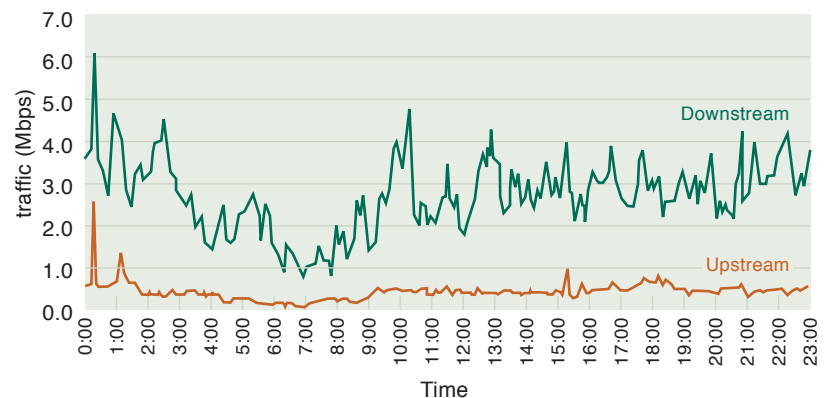

Figure 7 Daily average traffic

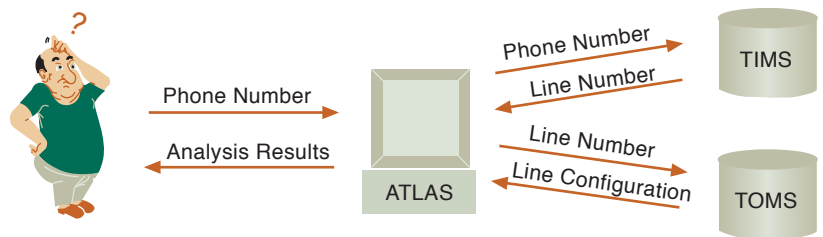

Figure 8 The integration of ATLAS, TIMS and TOMS

and TOMS. It can be also used for after-sale service and subscriber management.

3.4 ADSL Link Performance

Figure 9 and Table 7 show the measured ADSL link performance in KT. The speed of MEG-PASS LITE, 2 Mbit/s, is achievable for 93 % of users within 2 km, for example. In case ADSL speed cannot be guaranteed because of long loop, FTTC ADSL is deployed.

3.5 Crosstalk in the Field

When FTTC ADSL and CO ADSL coexist in the same binder, the loop length of FTTC ADSL is much shorter than that of CO ADSL. Thus, a

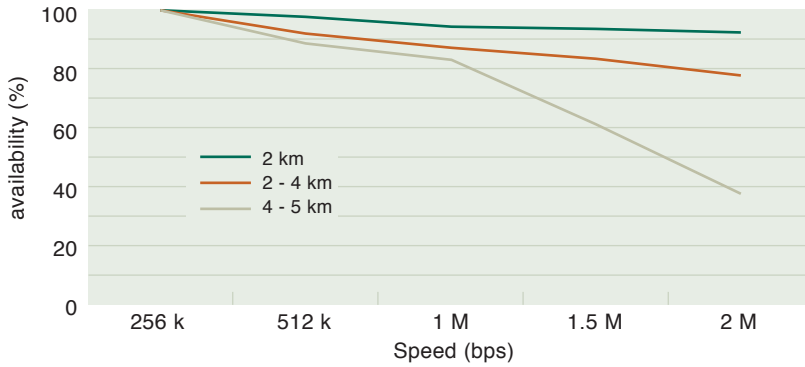

Figure 9 ADSL link performance graph

| Distance | ~ 256 kbit/s | ~ 512 kbit/s | ~ 1 Mbit/s | ~ 1.5 Mbit/s | ~ 2 Mbit/s |
|----------|--------------|--------------|------------|--------------|------------|
| ~ 2 km | 99.5 % | 97.5 % | 94.5 % | 94 % | 93 % |
| 2 ~ 4 km | 99.5 % | 92.5 % | 88 % | 84 % | 78.5 % |
| 4 ~ 5 km | 99.5 % | 89 % | 84 % | 62 % | 39 % |

Table 7 ADSL link performance chart

strong FTTC ADSL signal can cause self-FEXT to the attenuated CO ADSL signal, and it results in performance degradation of CO ADSL. According to the laboratory test, KT found that self-FEXT is not serious in the UTP cable but very serious in the CPEV cable.

To overcome this problem, we can consider three solutions. The first one is to update the current CPEV cables with UTP cables. For example, the performance degradation of UTP cable is merely 29 % at 4 km while it is 72 % for CPEV. More detailed data can be found in [3]. But updating old in-house cables with new ones is very expensive, and this solution is hardly realistic. The second solution is to reduce transmission power of FTTC ADSL. If FTTC ADSL signal power is equal to the attenuated CO ADSL signal power, there is no considerable self-FEXT between them. However, this solution may not be practicable because the service provider of FTTC ADSL can be different from that of CO ADSL. The last solution is to move the DSLAM out from the central office to a concentrated residential area. If so, CO ADSL turns to be FTTC ADSL, and there will be no considerable self-FEXT. In addition, the reduced loop length will improve ADSL service quality.

3.6 ADSL Interoperability (IOP)

ADSL IOP is necessary to guarantee the DMT chipsets from different vendors are fully compliant to G.992.1 DMT code. Proprietary implementations by different vendors were threatening ADSL IOP. However, interoperable ADSL is crucial for an open CPE market. If all ATU-C

and ATU-R are interoperable, the end user can buy his ADSL modem by himself in the market. Thus, KT has studied technical issues for ADSL interoperability. In the beginning of ADSL deployment, there were 8 DSLAM vendors, 21 CPE vendors, 4 ATU-C chipset vendors and 6 ATU-R chipset vendors. Some problems were brought to light by the test results; some transceiver functions such as overhead framing mode or interleaved delay were not interoperable between some systems. This kind of problem could be solved by firmware upgrade or restricting non-suitable functions. In contrast, ADSL link performance interoperability was a big problem. Chipset vendors had to make huge and contiguous efforts to make chipset or firmware code be any-to-any interoperable. For a detailed description of ADSL IOP in KT, [4] is recommended.

4 Future Steps

4.1 VDSL

In 2000, KT provided two types of VDSL trial services. The first one was a kind of Home LAN previously explained in section 2.3. The second one was traditional ATM mode VDSL and can be regarded as an extension of ADSL PREMIUM. Two trial services were carried out for 50 subscribers respectively. Even though ITU-T has not finalized G.vdsl series yet, KT has started to deploy NTOPIA-V (IP VDSL) into apartment complexes for commercial services. IP VDSL means VDSL with packet transfer mode defined in G.993.1 Annex H, PTM-TC. IP VDSL is purely for Internet access only and far from the Full Service originated from FSAN/FS-VDSL. The volume of current IP VDSL is not so huge at this stage.

4.2 PON

FSAN recommends Passive Optical Network (PON) to be the most cost-effective FTTC solution and has developed a G.983 series BPON specification. KT is planning to provide a BPON trial service in the winter of 2002. This trial service is basically based on the FSAN/FS-VSDL recommendation. In parallel, KT is also developing the KT GPON specification based on EFM EPON and FSAN GPON for service starting next year, if possible. PON will be deployed mainly for residential users but it is also suitable for a small number of business customers. To accommodate PON systems, KT is actively developing Optical Distribution Network (ODN) infrastructure such as broadband (BB) shelter, BB cabinet, BB box and their powering scheme [5].

4.3 Metro Ethernet and MSPP

KT has an active plan to deploy Metro Ethernet and Multi Service Provisional Platform (MSPP) for business customers. KT considers Metro

Ethernet to be suitable for business customers in small ISP/ASP or PC rooms, and MSPP is suitable for large and huge business customers in large ISP/ASP.

5 Summary

In this paper, we survey the overview, experiences and future steps of broadband access networks in KT. Broadband access has been successful in Korea and indicated a rapid growth during the last three years, but now it is thought to be saturated. We analyse basic factors of the rapid and large deployment of broadband access in Korea. To satisfy various customers' needs, KT has many types of broadband access such as central office based ADSL, FTTC ADSL, Home LAN and wireless LAN. Regional broadband network, Contents Delivery Network, branding and tariffs are also introduced for better understanding of broadband environment in KT. Then, some ADSL experiences from the field are shown; aggregated traffic pattern, loop management, link performance, crosstalk and interoperability. Finally, we give you an idea about on-going and future steps on KT broadband access networks including VDSL, PON, Metro Ethernet and MSPP.

6 Acronyms

| | |
|---------|--|
| ADSL | Asymmetric Digital Subscriber Line |
| ATLAS | ADSL Transmission Line Analysis System |
| ATM | Asynchronous Transfer Mode |
| ATU-C | ADSL Transmission Unit – Central |
| ATU-R | ADSL Transmission Unit – Remote |
| B&A | Building And Apartment |
| BPON | Broadband Passive Optical Network |
| B-RAS | Broadband Remote Access Server |
| CAT | Category |
| CATV | Cable TV modem |
| CDN | Content Delivery Network |
| CLI | Command Line Interface |
| CO | Central Office |
| COC | Central Office Concentrator |
| CPE | Customer Premises Equipment |
| DMT | Discrete Multi Tone |
| DSLAM | Digital Subscriber Line Access Multiplexer |
| EFM | Ethernet in the First Mile |
| EMS | Element Management System |
| EPON | Ethernet Passive Optical Network |
| FEXT | Far End Cross Talk |
| FTTC | Fiber To The Curb |
| F/E | Fast Ethernet |
| FSAN | Full Service Access Network |
| FS-VDSL | Full Service VDSL |
| GES | Giga Ethernet Switch |
| GPON | Gigabit per second Passive Optical Network |
| GSR | Giga Switch Router |
| KORNET | KOREa Telecom NETWORK |
| IOP | Interoperability |

| | |
|----------|---|
| MDU | Multiple Dwelling Unit |
| MIC | Ministry of Information and Communications |
| MSPP | Multi Service Provisional Platform |
| NEXT | Near End Cross Talk |
| NTOPIA-E | NTOPIA based on Ethernet |
| NTOPIA-S | NTOPIA based on SHDSL |
| NTOPIA-V | NTOPIA based on VDSL |
| OLT | Optical Line Termination |
| ONU | Optical Network Unit |
| PHY | Physical layer |
| POTS | Plain Old Telephone Service |
| PPP | Point-to-Point Protocol |
| PPPoE | PPP over Ethernet |
| P2P | Peer to Peer |
| PTM-TC | Packet Transfer Mode Transmission Convergence |
| SHDSL | Single-pair High-speed Digital Subscriber Line |
| SLA | Service Level Agreement |
| STM | Synchronous Transfer Mode |
| TIMS | Telephone-service Integration Management System |
| TLAN | Time-division duplex LAN |
| TOMS | Telephone Outside-plant Management System |
| UTP | Unshielded Twisted Pair |
| VDSL | Very high speed Digital Subscriber Line |
| WMP | Window Media Player |

References

- 1 Hongseok Kim et al. *VDSL deployment in KT – Overview and progress to date.* OHAN/FSAN 2001, 2.2-1 – 2.2-6.
- 2 Hyung-Ah Han et al. *The study on the management technologies for ADSL subscriber loop.* OHAN/FSAN 2001, 18-1–18-7.
- 3 Hyung-Ah Han et al. *xDSL Network Evolution Strategies to Minimize Crosstalk of FTTC-ADSL.* ISSLS 2002.
- 4 Myung-Jin Kang et al. *The status and test results of ADSL interoperability in KT.* OHAN/FSAN 2001, 17-1–17-8.
- 5 Sangki Hong et al. *Shared Powering system for B-PON Deployment.* ISSLS 2002, 113–118.